

EJOSYST®

„Captive Screw“

Legal specifications force manufacturers of parts and components to a captive locking of the fastening elements to the component. The fastener has to be connected to the component even if not yet fastened.

These properties can be achieved with the EJOT® fastening element “Captive screw“. The component, mainly developed for fastening plastic add-on parts, is pressed into the cylindrical hole of the plastic part.

With a spring, which is integrated into the system, the screw is kept in position and only after the clean alignment of the components the parts are fastened.

The components of the system are adjusted in such a way, that a relaxation-free connection is always ensured. The integrated drives (TORX® and knurl structure) facilitate a defined torque controlled installation and also an ergonomically convenient manual installation.

Application area

- Fixing of headlights mainly for lorries
- For fastening covers, trims and safety devices according to Machinery Directive 2006/42/ EG in general mechanical engineering

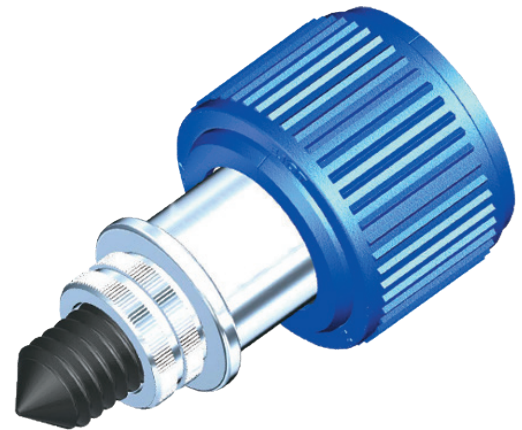

Advantages of the “captive screw“

- Clean positioning before fastening
- Ergonomically convenient assembly or rather pre-assembly by hand
- Torque controlled, automated installation possible
- Relaxation-free connection
- Variable colouring to prevent mix-up
- Low weight through the use of plastic material
- Variable resilience through exchangeable springs

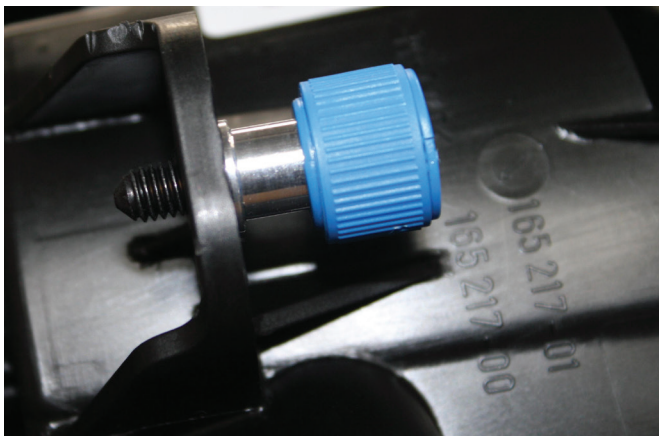

Technical Information

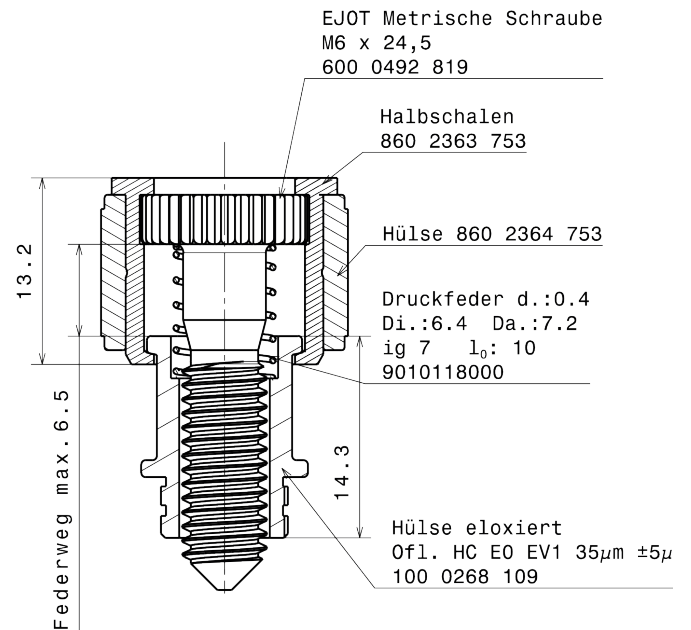
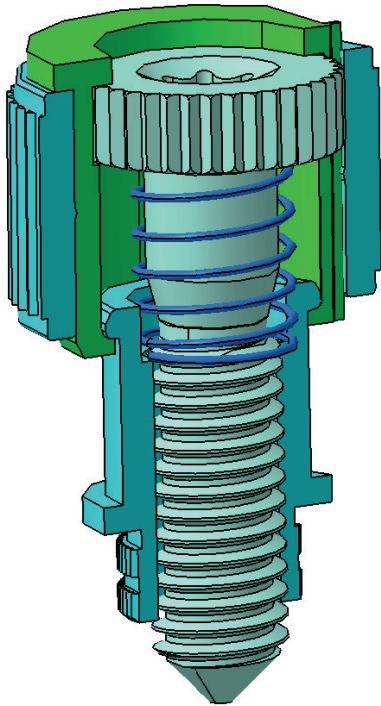

Installation advice

- Hole diameter $E = \varnothing 8.4 \text{ mm } (\pm 0.1)$
- Insertion height $F = 4.6 \text{ mm } (-0.2)$

Montagerichtung

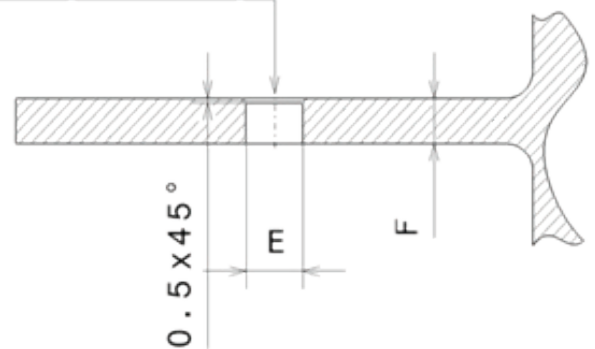

Material headlamp casing: PP -TV 40